



Quick Manual  
**eddyNCDT 3060**  
**eddyNCDT 3061**

MICRO-EPSILON  
MESSTECHNIK  
GmbH & Co. KG  
Königbacher Strasse 15

94496 Ortenburg / Germany

Tel. +49 (0) 8542 / 168-0  
Fax +49 (0) 8542 / 168-90  
e-mail [info@micro-epsilon.de](mailto:info@micro-epsilon.de)  
[www.micro-epsilon.com](http://www.micro-epsilon.com)

You can find more information about the measurement system in the instruction manual. This is available online at:

[www.micro-epsilon.de/download/manuals/man--eddyNCDT-3060--en.pdf](http://www.micro-epsilon.de/download/manuals/man--eddyNCDT-3060--en.pdf)

or on the CD supplied.

## General

### Symbols used

The following symbols are used in this document:



Indicates a hazardous situation which, if not avoided, may result in minor or moderate injury.



Indicates a situation that may result in property damage if not avoided.



Indicates a user action.



Indicates a tip for users.



Sensor measurement direction

### Warnings



Connect the power supply and the display/output device according to the safety regulations for electrical equipment.

> Risk of injury, damage to or destruction of the sensor and/or the controllers



Avoid shocks and impacts to the sensor and the controller.

> Damage to or destruction of the sensor and/or the controller

The supply voltage must not exceed the specified limits.

> Damage to or destruction of the sensor and/or the controller

Protect the sensor cable against damage.

> Destruction of the sensor, failure of the measurement system.

## Intended Use

- The measuring system is designed for use in an industrial environment. It is used for
    - measuring displacement, distance movement and thickness,
    - measuring the position of parts or machine components.
  - The measuring system must only be operated within the limits specified in the technical data.
- The measuring system must be used in such a way that no persons are endangered or machines and other material goods are damaged in the event of malfunction or total failure of the controller..
- Take additional precautions for safety and damage prevention in case of safety-related applications.

## Proper Environment

Controller	Ambient temperature	Storage temperature
	0 ... +50 °C (+32 ... +122 °F)	-10 ... +50 °C (+14 ... +122 °F)
Sensor, sensor cable <sup>1</sup>	Ambient temperature	Storage temperature
	-20 ... +180 °C (-4 ... +356 °F)	-50 ... +180 °C (-58 ... +356 °F)

Protection class	IP67 (when connected)
Humidity	5 - 95 % (non-condensing)
Ambient pressure	Atmospheric pressure

1) Temperature details apply for standard sensors

## Setup, Connection Options

Power supply and signal output are provided via plug connectors on the front of the controller.

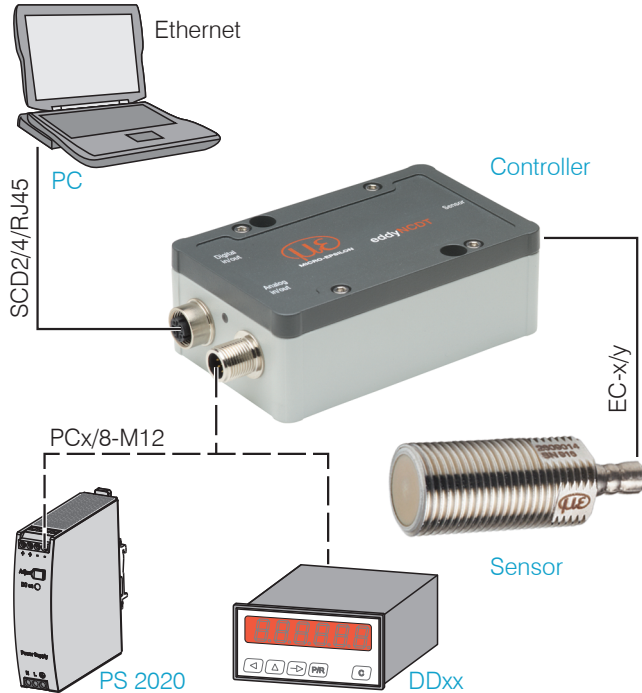

## Pin Assignment Supply, Analog Output

PIN	Wire color PCx/8-M12	Signal
2	brown	+24 VDC supply, polarity protection
7	blue	GND supply
1	white	U <sub>displacement</sub> (load min. 10 kOhm)
6	pink	GND displacement
8	red	I <sub>displacement</sub> (load max. 500 Ohm)
3	green	U <sub>temp sensor</sub> / threshold 1
4	yellow	U <sub>temp controller</sub> / threshold 2
5	gray	GND temperature, threshold
Shield		

The PCx/8-M12 is a fully assembled power- and output cable; length is 3, 5 or 10 m. The GND analog grounds are connected internally. The outputs are short circuit proof.

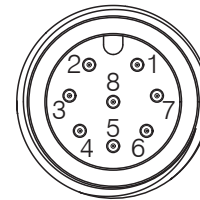

Pin side 8-pin housing plug

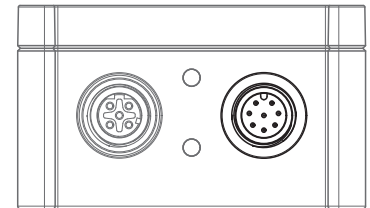

Supply and analog output controller, 8-pin male connector

## Measurement Setup, Operating Multiple Sensors

Sensors of the eddyNCDT 3060 series cannot be synchronized. Observe the following installation information regarding the minimum distance between two sensors:

- 3x sensor diameter distance between two unshielded sensors
- 1.5x sensor diameter distance between two shielded sensors
- two nearby mounted sensors only as low frequency and high frequency models

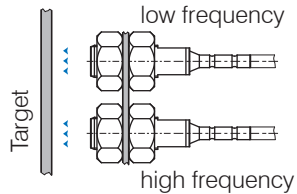
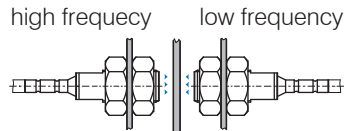
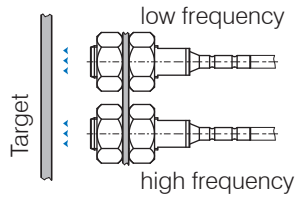

No synchronization required

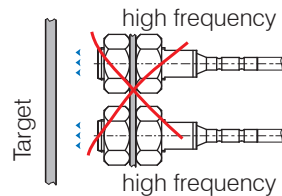
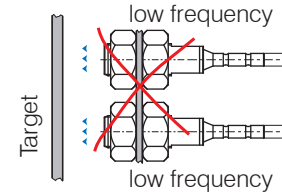
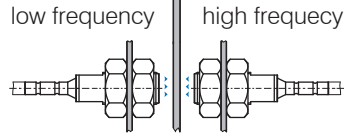

Not possible

## LED Controller, LED

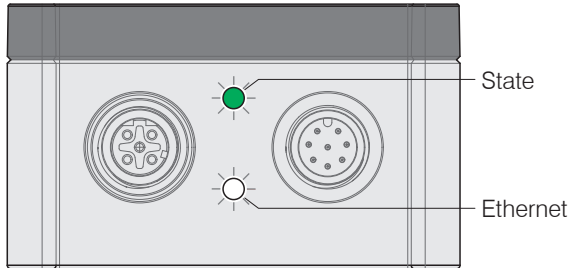

	LED State			
	green	orange	red	off
Controller in operation, measurement runs	●			
Software update	☀			
Sensor resp. target outside measuring range		☀		
No sensor connected, threshold or warn level exceeded, error			●	
No power supply				○

### Legend LED



## Glossary, Analog Output

- SMR** Start of measuring range. Minimum distance between sensor front and measuring, sensor specific
- MMR** Midrange
- EMR** End of measuring range (Start of measuring range + measuring range). Maximum distance between sensor front and measuring object.
- MR** Measuring range

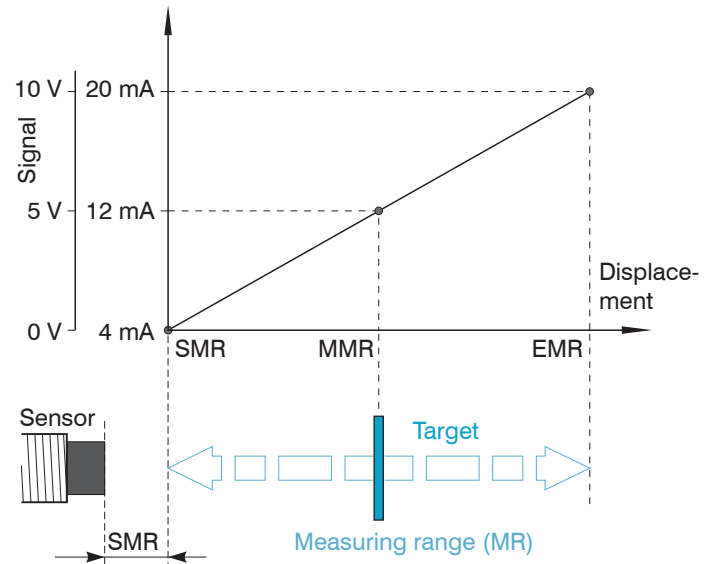

## Installation and Assembly

No sharp or heavy objects should be allowed to affect the cable sheath of the sensor cable, the supply cable and the output cable.

**i** A damaged cable cannot be repaired. Tension on the cable is not permitted!!

### Sensor

Unshielded sensors

- Type designation: ES-Ux
- Construction: The sensor cap with encapsulated coil consists of electrically non-conducting materials.

**i** In the radial direction metal parts in the vicinity may behave similar to the measuring object, rendering the measurement result inaccurate. Please note this by selection of material for sensor mounting and their setup.



Shielded sensors

- Type designation: ES-Sx
- Construction: The sensor enclosed up to its front face with a steel housing with a mounting thread. With it the sensor is shielded from interference through radially near located metal parts.



### Start of Measuring Range

For each sensor a minimum distance to the measuring object must be maintained. This avoids a measurement uncertainty due to the sensor pressing on the measuring object and mechanical damage to the sensor/target.

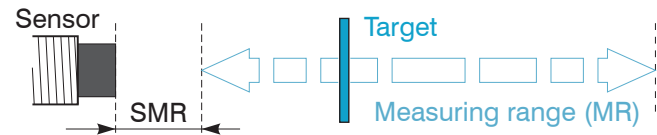

*Start of measuring range (SMR), the minimum distance between sensor face and target*

Eddy-current displacement sensors can be affected in their measurement properties by a metallic holder. Depending on the sensor type, the following sensor mounting should be preferred:

- unshielded sensors: Standard mounting
- shielded sensors: Flush mounting

## Standard Mounting

The sensors protrude beyond the metal holder. The installation scenario depicted is used for factory calibration of the sensors at Micro-Epsilon.

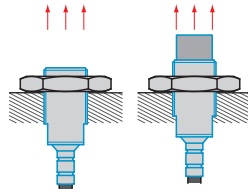

The technical sensor data correspond to standard installation conditions. If you want to achieve the values indicated in the data sheet, we recommend to install the sensor in the same way as it was during calibration.

### Sensors with a thread

- ▶ Insert the sensor through the hole in the sensor holder.
- ▶ Screw the sensor tight.
- ▶ Turn the mounting nuts from the delivery on both sides on the thread protruding from the holder.
- ▶ Tighten the mounting nuts carefully to avoid damage, particularly to smaller sensors.

• **i** Prefer the standard mounting of the sensor, because the optimum measurement results can be achieved with this method!

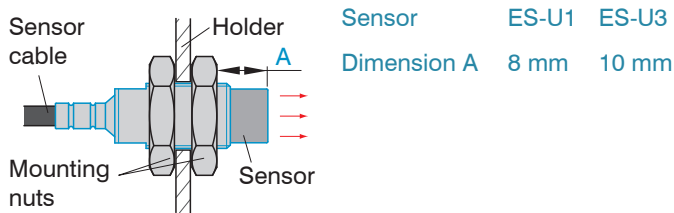

*Unshielded sensor with thread in standard mounting*

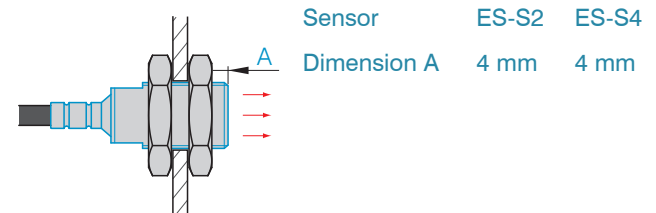

*Shielded sensor with thread in standard mounting*

• **i** During calibration maintain the same relative position of the sensor to the holder as for the measurement!

## Flush Mounting

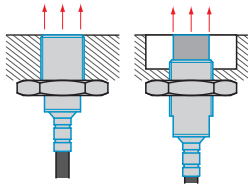

Flush mounting does not correspond to factory calibration. Micro-Epsilon recommends to carry out at least a 3-point field linearization.

**i** Linearize the measuring system, if possible, when it is exactly arranged (in the same way as it will be arranged later during the measurement process).

### Sensors with a thread

- ▶ Mount shielded or unshielded sensors flush in a sensor holder of insulating material (plastic, ceramic, et cetera).
- ▶ Mount the shielded sensors flush in a metal sensor holder.
- ▶ Mount the unshielded sensors flush in a metal sensor holder. Make sure that a recess of a size three times the sensor diameter is used.
- ▶ In all mounting cases screw the sensor into the threaded hole and lock it with the mounting nut.
- ▶ Tighten carefully to avoid damage, particularly to smaller sensors.

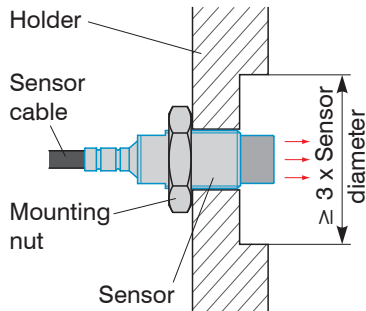

*Flush mounting of an unshielded sensor in a metal holder*

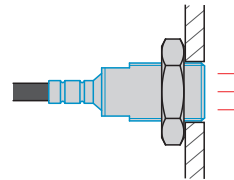

*Flush mounting of a shielded sensor in a metal holder.*

## Target Size

The relative size of the target object compared with the sensor affects the linearity and slope deviation for eddy current sensors.

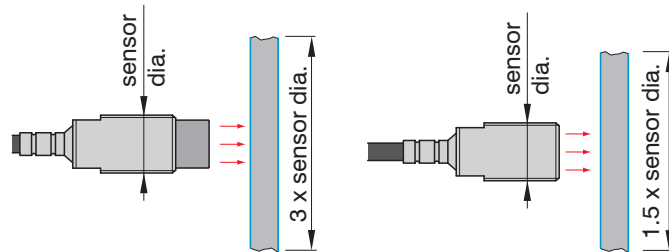

*Minimum target size for unshielded sensors*

*Minimum target size for shielded sensors*

If the required object minimum size cannot be complied with, the following aspects must be taken into account for a sufficiently high linearity:

- The size of the target must not change.
- The target must not be moved laterally to the sensor face.

A successful calibration is a prerequisite to minimize linearity errors.

In order to achieve an optimal result, Micro-Epsilon recommends a linearity calibration on the corresponding measuring object. A change of the measuring object size has significant effects on the quality of the measurement results.

## Sensor Cable

- ▶ Do not kink the cable - the minimum bending radius is 20 mm (static) respectively 40 mm (moved).
- ▶ Lay the cable such that no sharp-edged or heavy objects can affect the cable sheath.
- ▶ Connect the sensor cable to the controller.

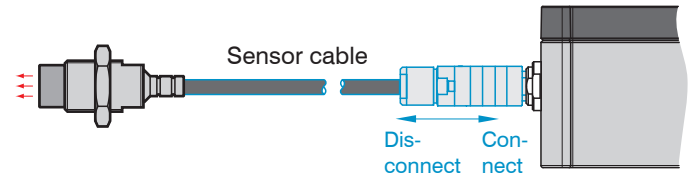

To release the plug-in connection, hold the plug-in connector on the grooved grips (outer sleeves) and pull apart in a straight line.

- Pulling on the cable and the clamping nut locks the connector and does not release the connection. Avoid the excessive pulling on the cables
- ▶ Check the plugged connections for firm seating.

## Controller

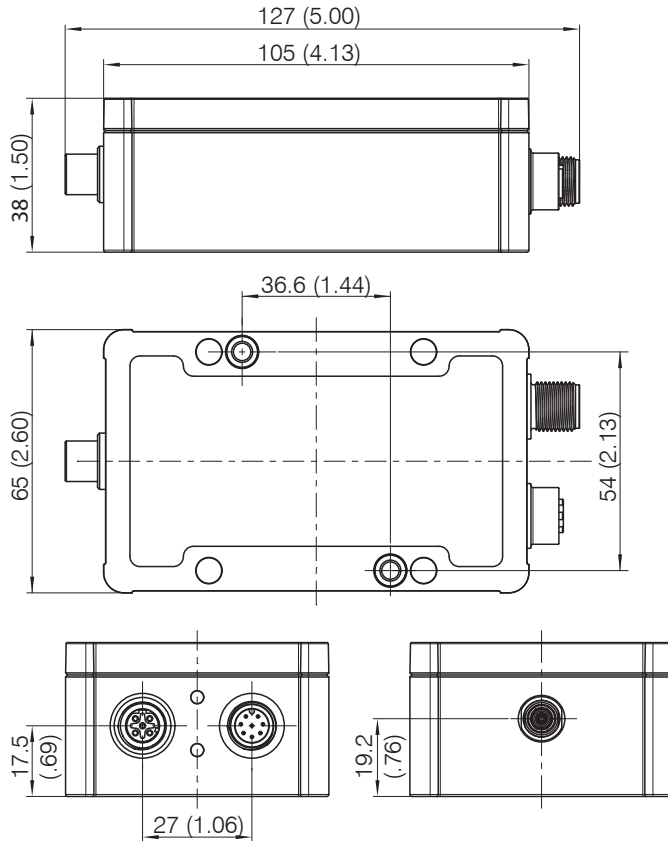

*Dimensional drawing controller*

## Operation Using Ethernet

The controller generates dynamic web pages, that contain the current settings of the controller and the peripherals. The operation is only possible as long as there is an Ethernet connection to the controller.

### Requirements

You need a web browser that supports HTML5 (e. g. Firefox  $\geq$  3.5 or Internet Explorer  $\geq$  10) on a PC with a network connection.

Use a LAN cable with M12 screw connection and RJ-45 connector, e.g. as SCD2/4/RJ45 cable available as optional accessory.

The controller is factory-set to direct connection with a static IP address to facilitate initial operation of the control.

If your browser is set to access the Internet via a proxy server, please add the controller IP address to the IP addresses in the browser settings, which are not to be routed over the proxy server. The MAC address of the measuring device is given on the controller rating plate. "Javascript" and "CSS" must be enabled in the browser so that measurement results can be displayed graphically.

Direct connection to PC		Network
PC with static IP	PC with DHCP	Controller with dynamic IP, PC with DHCP
<p>➡ Connect the controller to a PC via a direct Ethernet connection (LAN).</p>		<p>➡ Connect the controller to a switch.</p>
<p>➡ Start the SensorFinder.exe program.</p> <p>➡ Click the button <i>Start Scan</i>. Select the designated controller from the list. In order to change the address settings, click the button <i>Change IP...</i></p> <ul style="list-style-type: none"> <li>• Address type: static IP-Address</li> <li>• IP address: 169.254.168.150<sup>1</sup></li> <li>• Subnet mask: 255.255.0.0</li> </ul> <p>➡ Click the button <i>Apply</i>, to transmit the changes to the controller.</p> <p>➡ Click the button <i>Start Browser</i> to connect the controller with your default browser.</p> <p>1) Requires that the LAN connection on the PC uses, for example, the following IP address: 169.254.168.1.</p>	<p>Wait until Windows has established a network connection (connection with limited connectivity).</p> <p>➡ Start the SensorFinder.exe program.</p> <p>➡ Click the button <i>Start Scan</i>. Select the designated controller from the list.</p> <p>➡ Click the button <i>Start Browser</i> to connect the controller with your default browser.</p>	<p>➡ Enter the controller in the DHCP / register the controller in your IT department.</p> <p>The controller gets assigned an IP address from your DHCP server. You can check this IP address with the SensorFinder.exe program.</p> <p>➡ Start the SensorFinder.exe program.</p> <p>➡ Click the button <i>Start Scan</i>. Select the designated controller from the list.</p> <p>➡ Click the button <i>Start Browser</i> to connect the controller with your default browser.</p> <p>Alternatively: If DHCP is used and the DHCP server is linked to the DNS server, access to the controller via a host name of the structure „DT3060_&lt;serial number&gt;“ is possible.</p> <p>➡ Start a web browser on your PC. Type „DT3060_&lt;serial number&gt;“ the address bar of your web browser.</p>
<p>Interactive websites for programming the controller and peripherals now appear in the web browser.</p>		

## Access via Web Interface

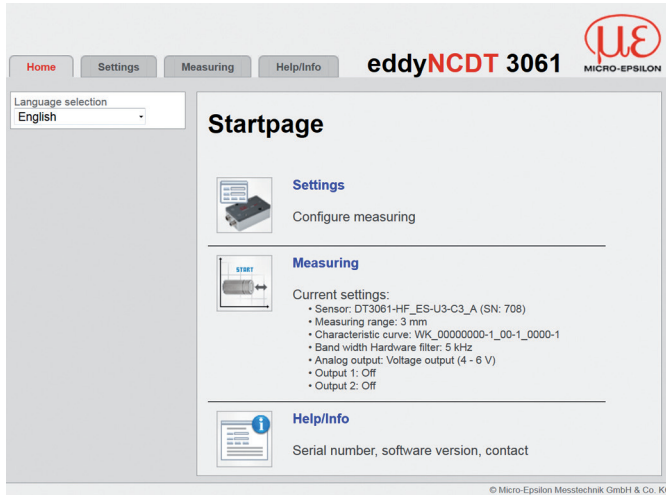

*Interactive website after selection of the web interface*

Additional help functions (e.g. Settings) are available in the top navigation bar. All settings on the web page are implemented in the controller immediately.

Parallel operation with web browser and Telnet commands is possible; the last setting applies.

The appearance of the web pages can change depending on the functions and the peripherals. Each page contains parameter descriptions and thus tips for configuring the controller.

## Operating Menu, Setting Controller Parameters

You can program eddyNCDT 306x using two different methods simultaneously:

- using the web browser via the sensor web interface
- using the ASCII command set and the terminal program via Ethernet (Telnet).

## Login, Change Access Authorization

➤ Menu Settings > Login.

Assigning passwords prevents unauthorized changes to controller settings. Password protection is not enabled as a factory setting. After the controller has been configured, you should enable password protection.

**i** A firmware update will not change a custom password.

User can do the following:

	User	Professional
Password required	no	yes
View settings	yes	yes
Change settings, linearization, analog output, password	no	yes
Start measuring	yes	yes
Scaling diagrams	yes	yes

*Permissions within the user hierarchy*

## Login

Logged in as

Password

*Change in the professional user level*

Enter the password into the Password box, and click Login to confirm.

Change to the User level by clicking the Logout button.

The user management enables to define a user-specific password in Professional mode.

Password	Value	All passwords are case-sensitive. Numbers are allowed, but special characters are not permitted.
<input type="text"/>	<input type="text"/>	

When a password is assigned for the first time, the field Old password remains empty.

## Scaling Measuring Range

➤ Menu Settings > Characteristics > Scale measuring range.

There are two ways to scale the measuring range of the eddyNCDT 306x:

- by using the mouse function directly in the graphic
- using the fields Current measuring range begin and Current measuring range end.

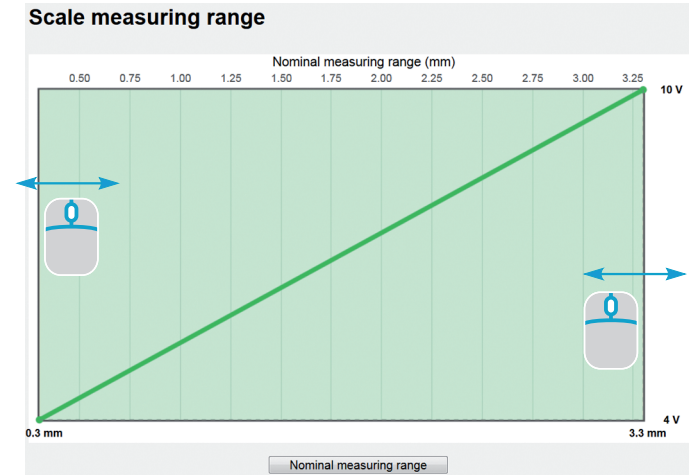

*Scaling the measuring range using the pointer*

Scaling of the measuring range has an effect on the analog and digital outputs without increasing the resolution.

### 3-Point Linearization

➤ Menu Settings > Characteristics > Carry out field linearization.

If the sensor or the measurement object is changed by the user, a calibration must be carried out before the measurement. Here, use the following if possible:

- the original sensor mounting,
- the original measurement object.

**I** Before a calibration is performed, the measuring device should warm up for about 30 minutes.

➤ Choose 3-point for linearization and the desired unit.

**Carry out field linearization**

Linearization type: 3-point  
 Unit for linearization: mm

Point 1	-	0.30000	mm	+	Submit
Point 2	-	1.80000	mm	+	Submit
Point 3	-	3.30000	mm	+	Submit

Linearize

**Save user characteristic curve**

Choose user characteristic curve: 1: FR AllMg

*Exemplary linearization using an ES-U3 sensor*

Sensor balancing occurs via three distance points which

eddyNCDT 306x

are specified by a comparison standard. You can freely choose the linearization points within the sensor measuring range.

➤ Place the measurement object to the sensor in point 1.

➤ Enter the measurement value (1).

Point 1:  mm

➤ Confirm point 1 with Submit.

➤ Repeat this procedure for the linearization points 2 and 3.

Linearize

**Save field characteristic**

Select field characteristic: 1: FR AllMg

Set name: FR AllMg

➤ Click on the button Linearize. The system executes the linearization.

You can permanently store the linearization result.

➤ Select a memory location for Field characteristic.

➤ Enter a description for the linearization in the field Set name.

➤ Click on the button Save & activate.

## Storage of Multiple Characteristic Curves

➤ Menu Settings > Characteristics > Select Characteristic.

The DT3060 can save one field calibration.

The DT3061 can save up to four different field calibrations, each build on a factory curve.

### Select characteristic

Select characteristic	Field curve 2: test5
Name	Factory curve 1: WK_00000000-1_00-1_0000-1
Type	Factory curve 2: WK_00000000-1_00-1_0000-1
Reference	Factory curve 3: WK_00000000-1_00-1_0000-1
	Factory curve 4: WK_00000000-1_00-1_0000-1
	Field curve 1: FLD 1
	Field curve 2: test5

Therefore, you can e.g. store different target or installation scenarios as individual characteristic curve and load them into the controller for the desired application.

## Import, Export

➤ Menu Settings > Manage settings.

### Export settings

Export settings

### Import settings

Choose settings file...

Controller settings  import

Ethernet settings  import

Import settings

Here you can export all controller settings in a file or reimport them from a file.

Controller settings Hardware filter, temperature settings, outputs

Ethernet settings IP address, subnet mask

## Scaling Temperature Analog Output<sup>1</sup>

➤ Menu Settings > Outputs > Temp ... 1/2.

The temperature output enables to output the controller or sensor temperature.

➤ Choose the types Temperature sensor or Temperature controller.

Max. output range: 0 V ... 5 V

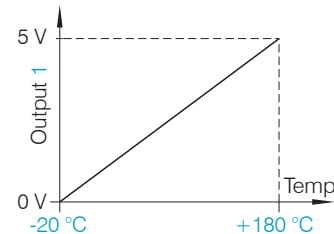

Sensor temperature

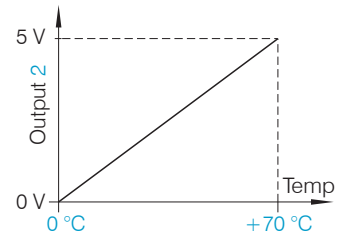

Controller temperature

The accuracy of the temperature measurement depends on the installation scenario. Reproducibility is high.

1) Function available with controller DT3061.

## Scaling Displacement Analog Output

➤ Menu Settings > Outputs > Displacement analog.

Max. output range: 4 mA ... 20 mA or 0 V ... 10 V

Output amplification  $\Delta I_{OUT}$  : 16 mA or  $\Delta U_{OUT}$  : 10 V; corresponds to 100 % MR

In every case, 2 points are used which characterize the start and the end of the analog output.

### Displacement, analog

Type of analog output:

Scaling of analog output

Start of range:  V

End of range:  V

Together with the Change scaling measuring range function, you can adapt the analog output to your individual requirements.

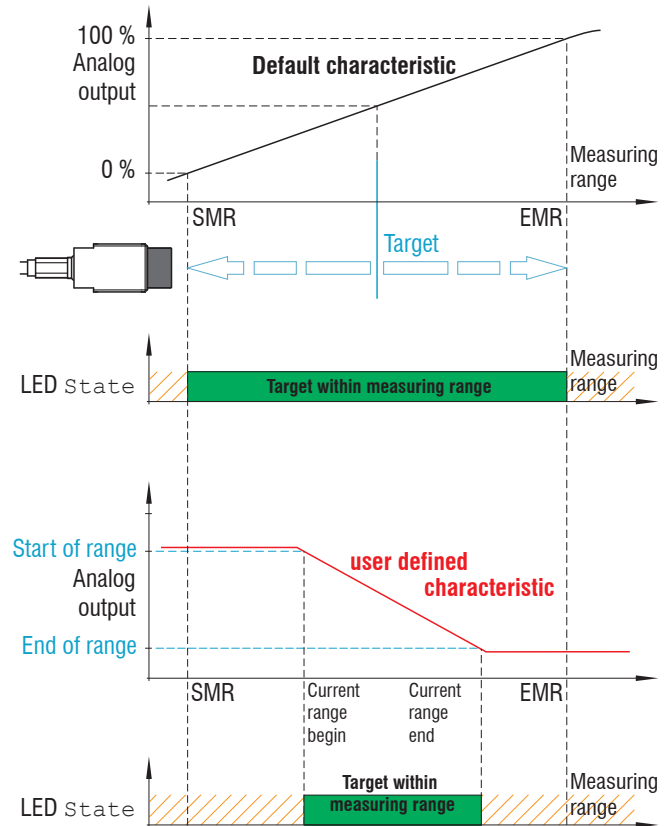

Default characteristic (black), reverse user defined characteristic (red)

## Limit Output<sup>1</sup>

➡ Menu Settings > Outputs > Limit value 1/2.

The eddyNCDT 3061 can check the measurement result to adjustable limits. This means that threshold values can be monitored, impermissible tolerances detected and sorting criteria realized.

The reference for the limit monitoring is selectable and applies to the current characteristic.

Type: Relative | Peak-To-Peak | Dynamic.

Relative	The threshold values A/B refer to the set Reference value
Peak-To-Peak	The threshold values A/B refer to the peak-to-peak value calculated in blocks (Peak-to-Peak $\Delta t$ parameter).
Dynamic	The threshold values A/B refer to a continuously calculated, moving average (Average $\Delta t$ ).

1) Function available with controller DT3061.

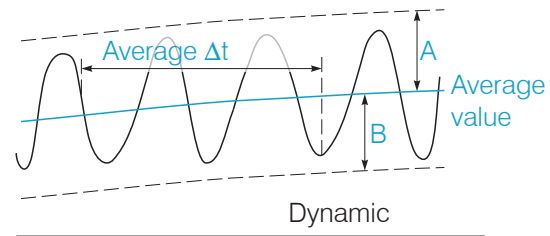
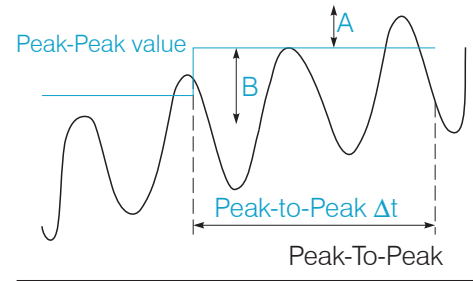
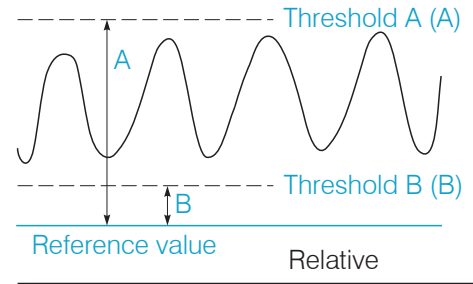

References for limit monitoring

## Temperature controller / Limit value 2

Type

Logic

### Limit value output

Type

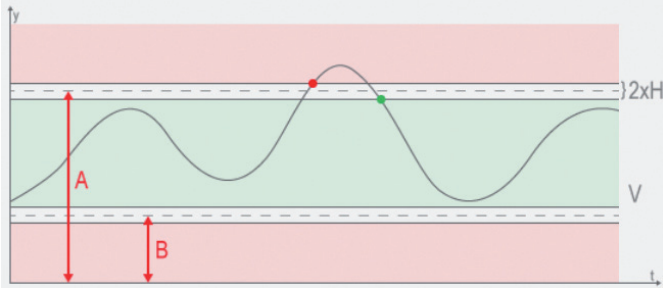

(V: Measuring value)

Threshold A  mm

Threshold B  mm

Reference value  mm

Hysteresis H  mm

Delay time  $t_1$   ms

Hold time  $t_2$   ms

Parameters for limit monitoring

eddyNCDT 306x

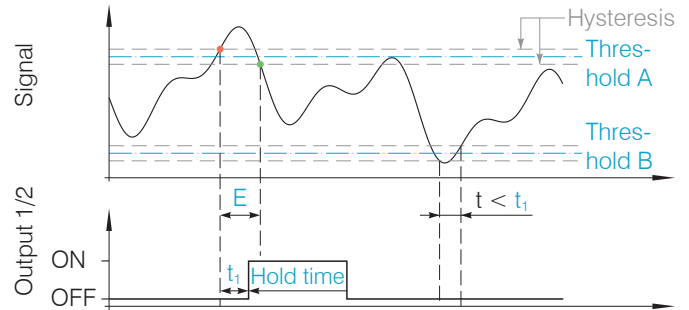

Timing limit monitoring, event (E) < hold time,  
logic: positive

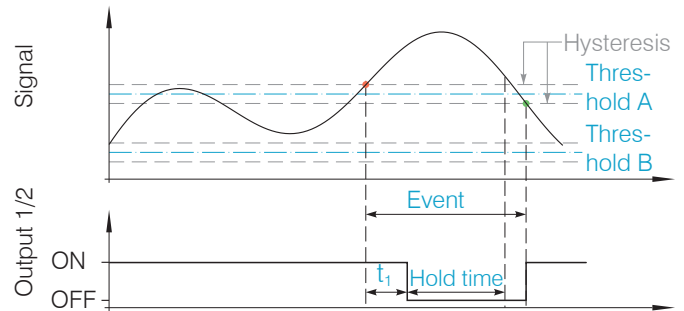

Timing limit monitoring, event (E) > hold time,  
logic: negative

- $t$  Duration of limit infringement
- $t_1$  Delay time
- $t < t_1$  Limit output passive
- $t \geq t_1$  Limit output active

## Positioning the Target

➡ Position the target within the sensor measuring range.

The value for the start of the measuring range (SMR) depends on the sensor. This value can be found in the technical data of the sensor.

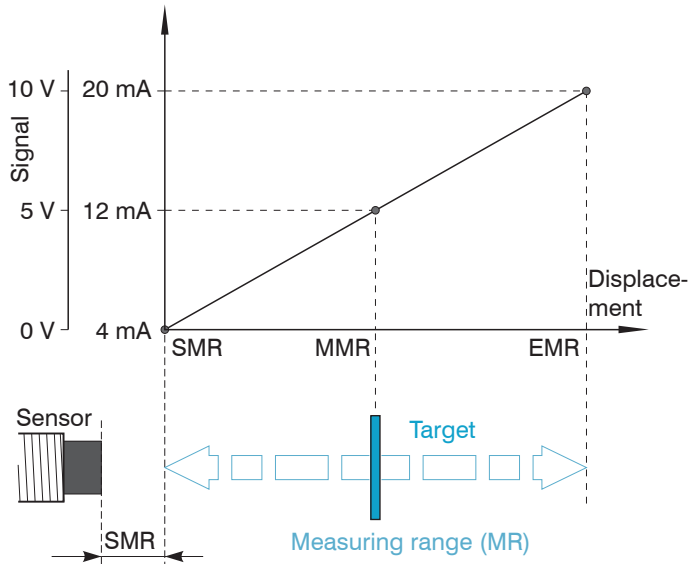

SMR Start of measuring range  
 MMR Midrange  
 EMR End of measuring range

## Displacement Measurements

➡ Switch to the Measuring > Measuring data display menu.

➡ Click the Start button.

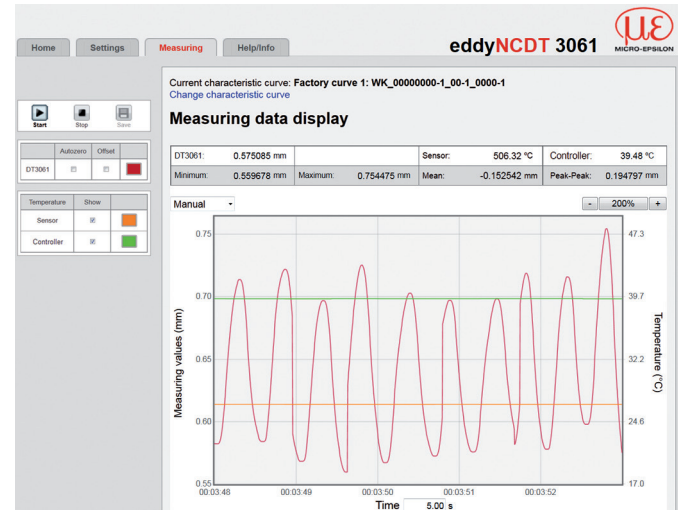

Statistic values are calculated in the web interface. Clicking onto the start/stop button starts/stops the calculation. At the beginning of a measurement, the statistic values are reset. During a measurement, the statistic values are updated with each new data package received by the controller.

## Service, Repair

In the event of a defect on the controller, sensor or sensor cable, the parts concerned must be sent back for repair or replacement. In the case of faults the cause of which is not clearly identifiable, the whole measuring system must be sent back to

MICRO-EPSILON MESSTECHNIK

GmbH & Co. KG

Königbacher Straße 15

94496 Ortenburg / Deutschland

Tel. +49 (0) 8542 / 168-0

Fax +49 (0) 8542 / 168-90

info@micro-epsilon.de

www.micro-epsilon.com

## Liability for Material Defects

All components of the device have been checked and tested for functionality at the factory. However, if defects occur despite our careful quality control, MICRO-EPSILON or your dealer must be notified immediately.

The liability for material defects is 12 months from delivery. Within this period, defective parts, except for wearing parts, will be repaired or replaced free of charge, if the device is returned to MICRO-EPSILON with shipping costs prepaid. Any damage that is caused by improper handling, the use of force or by repairs or modifications by third parties is not covered by the liability for material defects. Repairs are carried out exclusively by MICRO-EPSILON.

Further claims can not be made. Claims arising from the purchase contract remain unaffected. In particular, MICRO-EPSILON shall not be liable for any consequential, special, indirect or incidental damage. In the interest of further development, MICRO-EPSILON reserves the right to make design changes without notification.

For translations into other languages, the German version shall prevail.

## Model Designation Sensor

Eddy Sensor	Measuring range 1 / 2 / 3 / 4 mm	S = male connector C = integrated cable	Cable length [m]	A = mini B = normal C = large	Option
<b>ES - S 3 - C - S A 2,0 / m B 0 / □</b>					
S = shielded U = unshielded	C = cylindric F = flat	A = axial R = radial	m = male f = female OE = open ends	0 = straight 90 = right angle	

## Model Designation Sensor Cable

EC = eddy cable ECE = eddy cable extension	Controller side			
	m = male    A = mini f = female    B = normal    0 = straight OE = open ends    C = large    90 = right angle			
<b>EC - 3,0 / m A 90 / f B 0 / D3,9</b>				
Nominal cable length [m]	m = male    A = mini    0 = straight f = female    B = normal    90 = right angle OE = open ends    C = large			D = nominal cable diameter [mm]
	Sensor side			



MICRO-EPSILON MESSTECHNIK GmbH & Co. KG  
Königbacher Str. 15 · 94496 Ortenburg / Germany  
Tel. +49 (0) 8542 / 168-0 · Fax +49 (0) 8542 / 168-90  
info@micro-epsilon.de · www.micro-epsilon.de

X9691385-A011048MSC

© MICRO-EPSILON MESSTECHNIK

