

# QFA-125-30-LC Series High Temperature, Low Input Current Quartz Flexure Accelerometer



*Making Sense out of Motion...*

The Jewell Instruments QFA-125-30-LC Series Accelerometer contains state of the art quartz flexure technology that provides high accuracy, repeatability and stability in extremely high temperature environments with a low current input.



## Square Flange - Outline Drawing

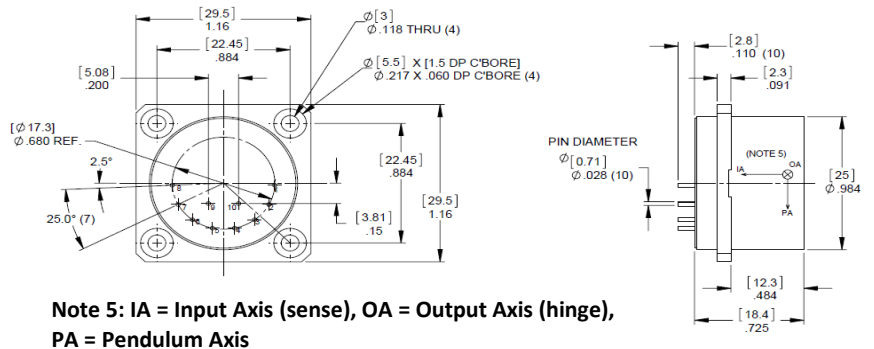

## Features & Benefits

- High Temperature
- Excellent Repeatability
- High Accuracy
- Environmentally Rugged
- High Stability
- Square or Round Mounting Flanges
- Small Compact Design
- Built-in Self Test System
- Low current

## Circle Flange - Outline Drawing

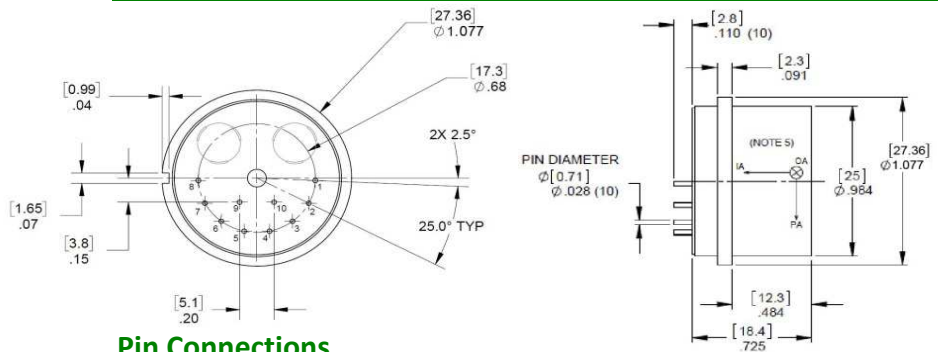

## Applications

- Well borehole logging (Wireline)
- Measure While Drilling (MWD)
- Oil Drilling
- Orientation Systems for Drilling Applications
- Borehole Mapping

## Pin Connections

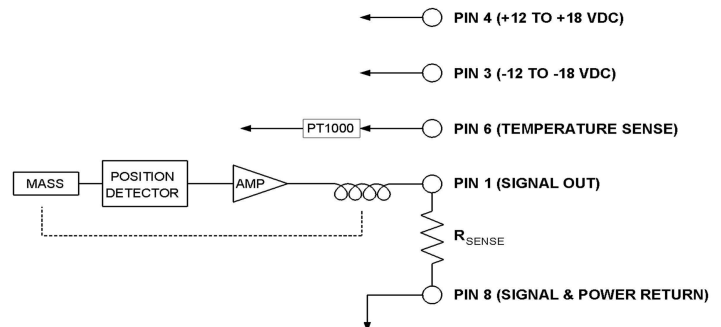

# QFA-125-30-LC Series High Temperature, Low Input Current Quartz Flexure Accelerometer



*Making Sense out of Motion...*

## Performance Specifications

### Performance

Acceleration Range, g Max. (Note 1)	±30
Scale Factor, mA/g (Note 2)	1.1 to 1.4
Bias, milli-g, Max. (@ 25° C)	40
Axis Alignment, mRad, Max. (@ 25° C)	1.5
Threshold and Resolution, µg, Max.	10
Bandwidth, Hz, Min.	300
Scale Factor Temp. Sens, PPM/°C, Max. (Note 3):	
+55°C to +180°C	±200
+100°C to +180°C	±170
Bias Temp. Sens, µg/°C, Max.	±100
Scale Factor Stability (1 month composite)	less than 250 ppm
Bias Stability (1 month composite)	less than 250 µg
Noise, mgrms, Max. (0Hz to 10kHz) (Max.)	3
Weight (grams)	55

### Electrical

Input Voltage, Vdc	±12 to ±18
Input Current, mA	+/-13mA max @ +/-18Vdc input +/- 10mA nominal @ +/-15Vdc input +/- 8mA nominal @ +/-12Vdc input
Output Impedance, ohms	External Load Resistor Dependent

### Environmental

Operational Temp Range, °C	-55°C to +125°C
Vibration, (Sine)	25 Hz to 500 Hz, 25g
Vibration, (Random) Rectification, µg/g <sup>2</sup> rms	50 Hz to 500 Hz, 100 µg/g <sup>2</sup> rms
Shock, g (0.5 msec, 1/2 sine)	1000

Note 1: Specifications apply and are characterized up to ±1g range. The accelerometer is capable of supplying acceleration information up to ±30g but at reduced accuracy.

Note 2: Voltage output via customer supplied load resistor.

Note 3: Scale factor shown in mA/g as a standard. If you require scale factor in volts/g, please specify voltage range when ordering

\*Specifications subject to change without notice on account of continued product development

## How to Order

Model #	Part #	Accelerometers exported from the United States must be done in accordance with the Export Administration Regulations (EAR) and/or the International Traffic in Arms Regulations (ITAR) as applicable.
QFA-125-30G-SQ-LC	848 205-002	
QFA-125-30G-RD-LC	848 206-002	

**Jewell Instruments LLC**, 850 Perimeter Road, Manchester, NH 03103  
sales@jewellinstruments.com • www.jewellinstruments.com • Tel (800) 227-5955