

DD245PC - Process displays for analogue sensors

- Display 6-digits
- Connection: Two one-channel analogue sensors
- Two limits as relay outputs
- Calculation function
- Three analogue outputs
- Peak value memory
- Interface RS232



DD245PC has two analog inputs for connecting two sensors. With F1 and F2, the signals are shown on the display. The measured signals F1 and F2 are calculated internally and output via F3 (e.g. thickness). In addition, F1, F2 and F3 (0 ... +10 V) can be output via programmable analog outputs A1 - A3 to control processes. Two limits P1 and P2, that may be assigned at, will enable monitoring of production processes.

Dimensions (Dimensions in mm, not to scale.)

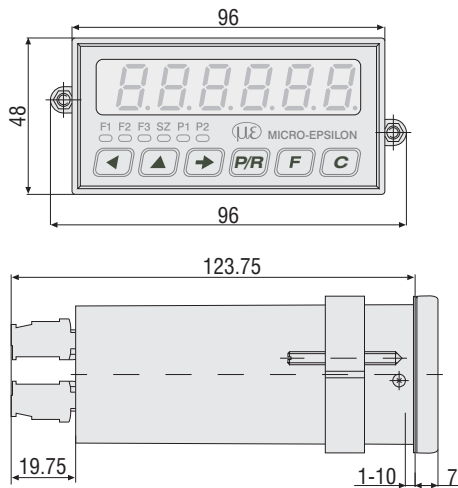

Block circuit diagram

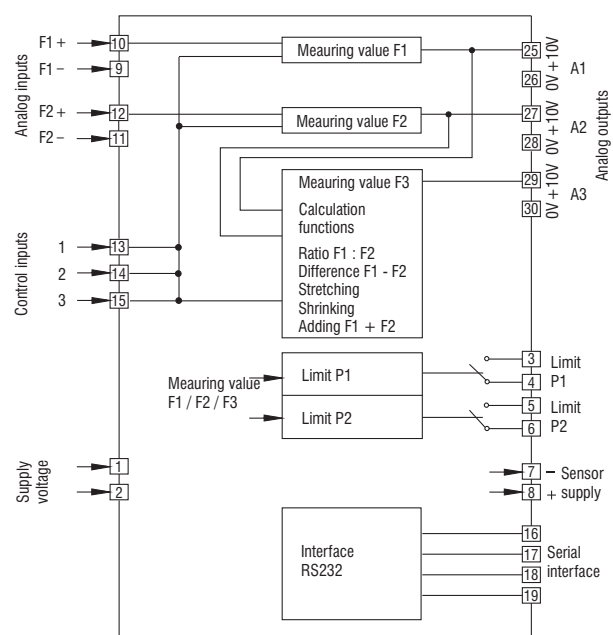

Technical data - electrical ratings	
Power supply	18...30 VDC
Power consumption	7 VA, 5 W
Sensor supply	18 VDC \pm 10% / 350 mA
Display	LED, 7-segment display
Number of digits	6-digits
Digit height	14 mm
Function	Digital display of 2 analogue measured values, peak value memory (slave pointer)
Measuring principle	Analogue resolution 12 bit
Signal inputs	Comparator inputs
Input logic	NPN / PNP
Control inputs	2 inputs
Control functions	Start, Stopp
Data memory	> 10 years in EEPROM
Analogue input	0(4)...20 mA, resolution 12 bit, temp. coeffic. typ. \pm 20 ppm/ $^{\circ}$ C
Outputs relay	Potential-free change-over contact
Analogue output	3 analogue outputs 0...+10 V, resolution 12 bit, temp. coeffic. typ. \pm 20 ppm/ $^{\circ}$ C
Interfaces	RS232
Standard DIN EN 61010-1	Protection class II, overvoltage category II, pollution degree 2
Emitted interference	DIN EN 61000-6-3
Interference immunity	DIN EN 61000-6-2
Programmable parameters	Analogue inputs and outputs, 2 limits, control inputs, calculating functions, offset (maximum and minimum analogue limit)
Approvals	UL/cUL, CE conform

Technical data - mechanical design	
Temperature	Operating: -10...+50 $^{\circ}$ C; storage: -20...+70 $^{\circ}$ C
Relative humidity	80 % non-condensing
Core cross-section	1.5 mm ²
Protection DIN EN 60529	IP 65 face with seal
Operation / keypad	Membrane with softkeys
Housing type	Housing for control panel installation
Dimensions	W x H x L 96 x 48 x 124 mm
Cutout dimensions	96 x 45 mm (+0.6)
Installation depth	123.75 mm
Mounting	Front panel installation by clip frame
Weight	approx. 350 g (AC), 250 g (DC)
Material	Housing: Makrolon 6485 (PC)